

GATE VALVE

HAND WHEEL OPERATED

APPLICABLE STANDARD

DESIGN STD. : API 600/ API 6D/ BS 5155
 TESTING STD. : API 598/ BS 5146
 RATING : 150#/ 300#/ 600#
 DRILLING : AS PER ANSI B 16.5
 FACE TO FACE : AS PER ANSI B 16.10
 OPERATION : HAND WHEEL OPERATED
 END CONN. : FLANGED END (RF)

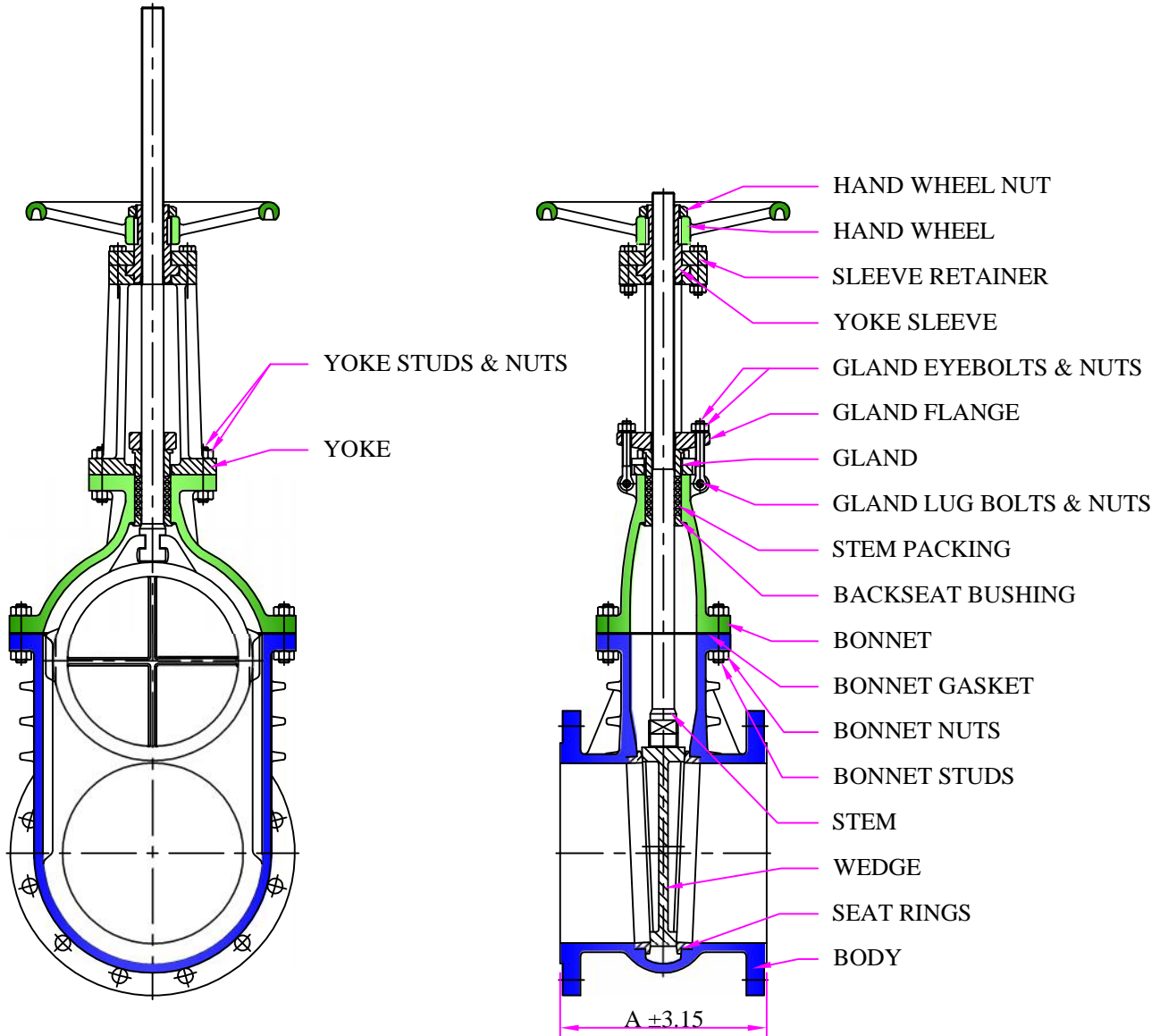

VALVE SIZE - INCH	8"	10"	12"	14"	16"	18"	20"	24"	26"	28"	30"	32"	36"	
VALVE SIZE - MM	200	250	300	350	400	450	500	600	650	700	750	800	900	
A	150#	292.0	330.0	355.6	381.0	406.0	432.0	457.0	508.0	559.0	609.6	609.6	711.0	
	300#	419.0	457.0	501.6	762.0	838.0	914.0	990.6	1143.0	1244.6	1346.0	1397.0	1542.0	1727.0
	600#	660.0	787.0	838.0	889.0	990.6	1092.0	1194.0	1397.0	1448.0	1549.0	1651.0	1778.0	2083.0



FLOW-TEK VALVES & CONTROLS INC

PLOT NO: 172-173, ROAD NO. 4, G.I.D.C.,
 KATHWADA, AHMEDABAD - 382430
 (M) : 09824080899, 09824539702
 PHONE : (079) 22900220, 22900219
 E-MAIL : info@flowagevalves.com, hemal21386@gmail.com
 url : www.delugecontrolvalve.com, www.flowagevalves.com
 AN ISO 9001:2008 CERTIFIED COMPANY